



Independent Healthcare Service Ltd.

EXPORT



# Sluicemaster | Classic<sup>+</sup>

Bedpan Disposal Technology



Working Together With Care...



# Sluicemaster Classic<sup>+</sup>

Bedpan Disposal Technology



## Smaller and more ergonomically designed

The Classic<sup>+</sup> is the base model but still possesses all the advantages of the Sluicemaster pedigree. Clad in robust, easy to clean stainless steel the Classic<sup>+</sup> is small enough to fit into benching, while standing up to knocks in the busy sluiceroom. Running on only cold water, electricity is not wasted heating water.

### The Classic<sup>+</sup> offers great performance with proven reliability

Outstanding benefits of the Classic<sup>+</sup> :-

- Efficient disposal of up to four pulp products in under two minutes, using only 24 litres of water
- Simple operation, Pans in, close hopper, press start
- Microprocessor control advises on status of system during disposal cycle and self-diagnosis of problems
- Bugban<sup>®</sup> – Antimicrobial built in, wipe clean exterior
- Front and top access for all components
- 12 months Parts Warranty.



### Dimensions

Sluicemaster Classic<sup>+</sup>  
Height: 940mm Depth: 620mm Width: 430mm

# Sluicemaster Classic<sup>+</sup> - Installation & Technical Data

## Installation planning

Maximum run to drain 2 metres with a minimum fall of 1:25.

Minimum waste pipe size 50mm (2").

Use swept bends not 90° degree bends.

## Cold water supply

Mains pressure. Ensure supply line is at no point less than 15mm.

## Electrical supply

Classic<sup>+</sup> can be supplied as either a single or three phase machine which must be connected to a 13 Amp fused spur switch (customer supply).

The electrical supply must be to current I.E.C. regulations using the supplied two metre flying lead. The appliance must be connected to a protective earth connection.

## Drainage

The machine is fitted with a 50mm (2") trap inside the cabinet. Ensure the route to the soil stack is shortest with minimum number of bends.

Please refer to the manual supplied with the machine for latest information and installation details as we continuously improve our products over time.

## Electrical Supply

Volts	Watts	Isolator Fuse	Water Consumption	Cycle Time	Max Loading	Weight (Dry)
240 / 1 / 50	590W	13A	24 ltr / cycle	115 seconds	4 Bedpans	85Kg
400 / 3 / 50	590W	6A	24 ltr / cycle	115 seconds	4 Bedpans	85Kg

## Full dimensions

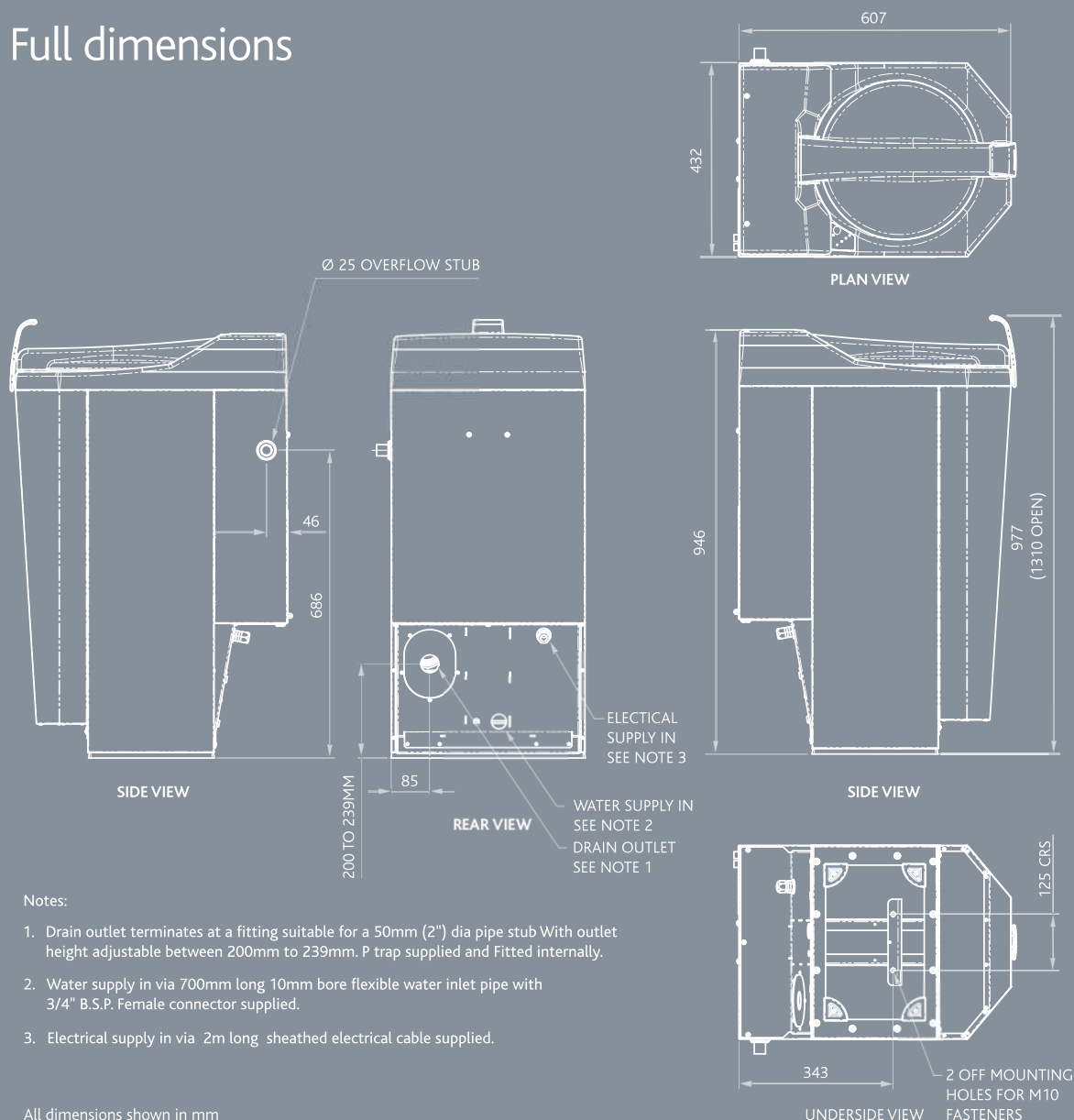

### Notes:

1. Drain outlet terminates at a fitting suitable for a 50mm (2") dia pipe stub With outlet height adjustable between 200mm to 239mm. P trap supplied and Fitted internally.
2. Water supply in via 700mm long 10mm bore flexible water inlet pipe with 3/4" B.S.P. Female connector supplied.
3. Electrical supply in via 2m long sheathed electrical cable supplied.

All dimensions shown in mm



*Independent Healthcare Service Ltd.*

*Unit 3 Westpoint Business Park,  
Mulhuddart, Dublin 15.*

**SALES & SERVICE**

**Tel: 01 443 3390**

**Email: [info@ihsltd.ie](mailto:info@ihsltd.ie)**

**Website: [www.ihsltd.ie](http://www.ihsltd.ie)**

*Working Together With Care...*